

# Determination of Flurazepam and Its Major Biotransformation Products in Blood and Urine by Spectrophotofluorometry and Spectrophotometry

J. ARTHUR F. de SILVA and NORMAN STROJNY

**Abstract** □ A spectrophotofluorometric assay for the determination of flurazepam and its major metabolites in blood and in urine was developed. It was applied to the determination of blood levels and urinary excretion in a dog following intravenous and oral administration and in two human subjects following the oral administration of flurazepam · 2HCl. In the two human subjects, 51 and 56% of the administered doses were recoverable in the 0-48-hr. urine as known metabolites.

**Keyphrases** □ Flurazepam and metabolites—spectrophotofluorometric assay, blood, urine, dog, human □ Spectrophotofluorometry—assay, flurazepam

Flurazepam [7-chloro-1-(2-diethylaminoethyl)-5-(2-fluorophenyl)-1,3-dihydro-2*H*-1,4-benzodiazepin-2-one · 2HCl] (I) was synthesized by Sternbach *et al.* (1) and is marketed as a hypnotic<sup>1</sup>. The major metabolites of

pound (V) in the dog by the oxidation of the alcohol side chain to a carboxylic acid.

The chemical structures of flurazepam and its major metabolites are given in Scheme I and Table I. The chemical synthesis of the acidic metabolite (V) was reported by Fryer and Earley (5). The 1,4-benzodiazepin-2-ones all undergo acid hydrolysis to yield their respective benzophenones (5-7), which in turn are cyclized in an alkaline medium to yield the 9-acridanone derivatives (8) (Scheme I).

The spectrophotofluorometric assay described for the determination of flurazepam and its major metabolites in blood and urine involves the following: selective extraction into diethyl ether from blood buffered to pH 9.0 or urine made alkaline with NaOH, and back-extraction into 4 *N* HCl followed by hydrolysis at 100° for 2 hr.

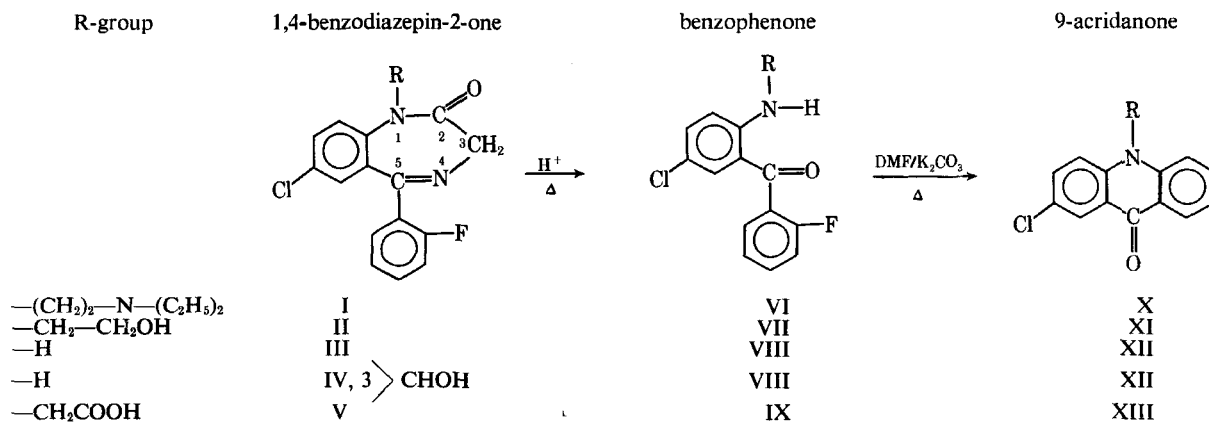

Scheme I—Chemical reactions of *N*-1-alkyl-substituted 2'-fluoro-1,4-benzodiazepin-2-ones

flurazepam in human and dog urine were characterized by Schwartz *et al.* (2) using TLC and mass spectrometry. The chemical synthesis of these compounds was reported by Earley *et al.* (3). Studies on the metabolism of <sup>14</sup>C-flurazepam · 2HCl (4) showed that it was extensively metabolized in both species to yield measurable amounts of the hydroxyethyl (II) and *N*-desalkyl metabolite (III) in the blood, which was further metabolized to the 3-hydroxy analog (IV) present in trace amounts in urine as a glucuronide conjugate. In addition, they showed that both I and II were metabolized to an acidic com-

to yield the respective benzophenones.

The benzophenones are extracted into diethyl ether (from the hydrolysate after making it alkaline with NaOH), the residue of which is reacted in dimethyl formamide, using K<sub>2</sub>CO<sub>3</sub> as a catalyst at 100° for 2 hr. to effect the cyclization to the 9-acridanone derivatives. These derivatives are extracted into diethyl ether and separated by TLC, and their fluorescence is determined in 80:20 methanol-0.1 *N* HCl (after elution from the silica gel) at their respective maxima of activation and emission (Fig. 1). The fluorescence yield of the 9-acridanones is sufficiently high and linear with concentration to enable their quantitation in the range of 0.003-10.0 mcg. of compound/ml. of blood or urine (Fig. 2).

<sup>1</sup> Flurazepam · 2HCl is the active drug substance in the pharmaceutical formulation Dalmane, marketed by Hoffmann-La Roche Inc., Nutley, N. J.

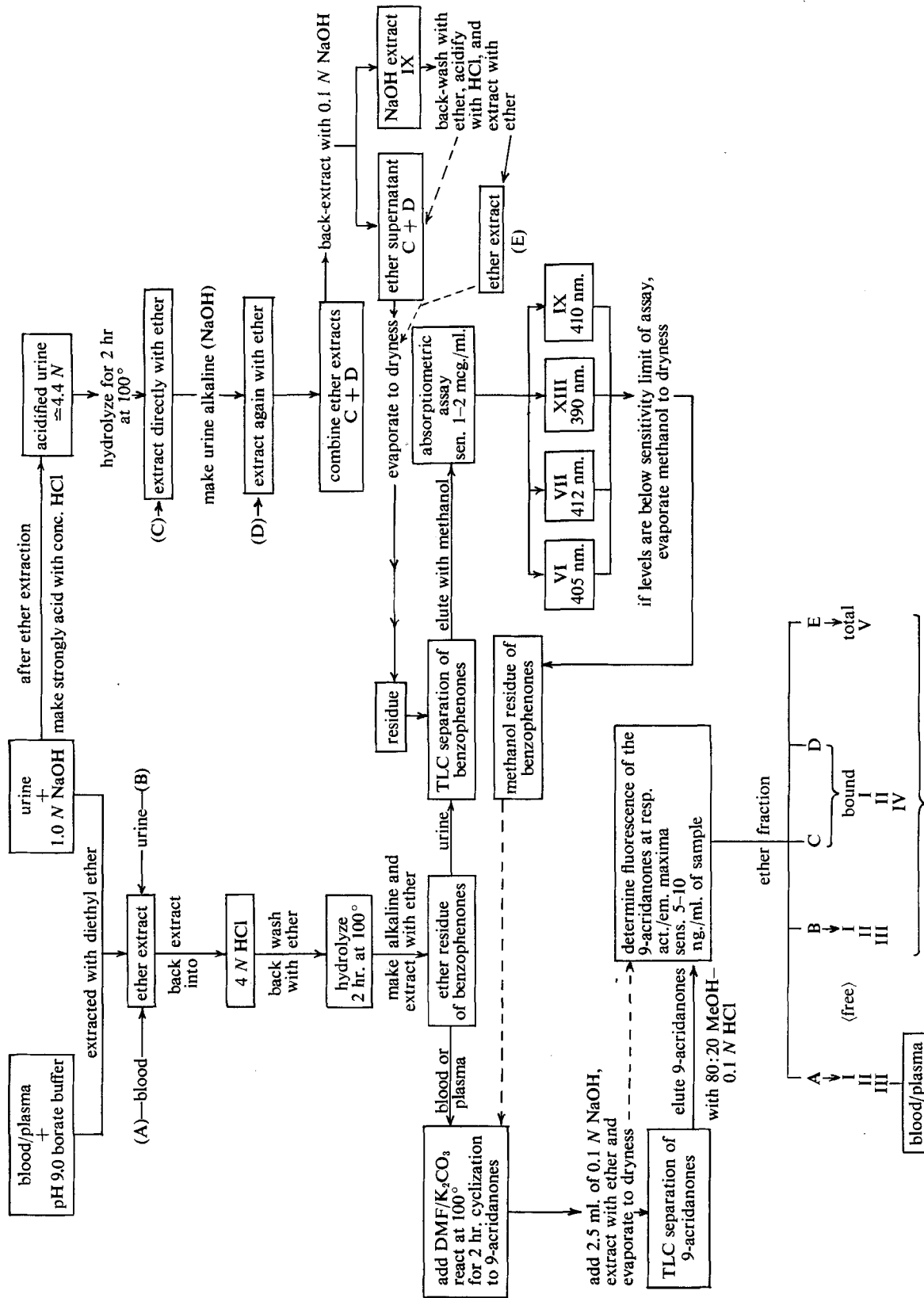

Scheme II—Flow diagram of the differential extraction procedure

**Table I**—Chemical Names and Compound Reference Nomenclature of the Benzodiazepin-2-ones, Benzophenones, and 9-Acridanones Referred to in Scheme 1<sup>a</sup>

Compound	Generic Name	Chemical Name	Molecular Weight	Melting Point	Reference to Synthesis
<b>1,4-Benzodiazepin-2-ones:</b>					
I	Flurazepam	7-Chloro-1-(2-diethylaminoethyl)-5-(2-fluorophenyl)-1,3-dihydro-2H-1,4-benzodiazepin-2-one · 2HCl	460.83	190–220° (dec.)	1
II	N-1-Hydroxyethyl-flurazepam	7-Chloro-1-(2-hydroxyethyl)-5-(2-fluorophenyl)-1,3-dihydro-2H-1,4-benzodiazepin-2-one	332.76	110–115°	3
III	N-1-Desalkyl flurazepam	7-Chloro-5-(2-fluorophenyl)-1,3-dihydro-2H-1,4-benzodiazepin-2-one	288.5	205–206°	1
IV	N-1-Desalkyl-3-hydroxyflurazepam	7-Chloro-5-(2-fluorophenyl)-3-hydroxy-1,3-dihydro-2H-1,4-benzodiazepin-2-one	304.72	195–198°	3
V	Flurazepam-N-1-yl-acetic acid	2-[7-Chloro-5-(2-fluorophenyl)-1,3-dihydro-2-oxo-2H-1,4-benzodiazepin-1-yl]acetic acid	346.76	216–225° (dec.)	5
<b>Benzophenones:</b>					
VI	—	5-Chloro-2-(2-diethylaminoethylamino)-2'-fluorobenzophenone · HCl	385.30	134–143°	5
VII	—	5-Chloro-2'-fluoro-2-(2-hydroxyethyl)amino-benzophenone	293.73	96–101°	5
VIII	—	2-Amino-5-chloro-2'-fluorobenzophenone	250.00	94–95°	5
IX	—	2-[4-Chloro-2-(2-fluorobenzoyl)]glycine	307.72	162–168°	5
<b>9-Acridanones:</b>					
X	—	2-Chloro-10-(2-diethylaminoethyl)-9-acridanone · HCl	365.32	265–275°	5
XI	—	2-Chloro-10-(2-hydroxyethyl)-9-acridanone	273.70	216–219°	5
XII	—	2-Chloro-9-acridanone	229.66	>350°	5
XIII	—	2-Chloro-10-(carboxymethyl)-9-acridanone	287.71	335–345° (dec.)	5

<sup>a</sup> The benzophenones were prepared by the acid hydrolysis of their respective benzodiazepin-2-ones and were recrystallized as their hydrochloride salts or bases (5) [using modifications of published procedures (6, 7)]. The 9-acridanones were prepared from their respective benzophenones (5) using the published procedure (8).

The assay was modified to employ selective extraction procedures for the determination of flurazepam and its major metabolites in the free and bound (conjugated) forms in urine, either by spectrophotometry as their benzophenones or by spectrophotofluorometry as their respective 9-acridanones.

TLC was used to separate the different reaction products, thus imparting the required specificity for the

quantitation of each compound. A flow diagram of the differential extraction procedure is shown in Scheme II.

The method was applied to the determination of the blood levels and urinary excretion of flurazepam and its major metabolites in a dog following the oral and intravenous administration of a 5-mg./kg. dose and in man following the administration of single 90-mg. oral doses of flurazepam · 2HCl.

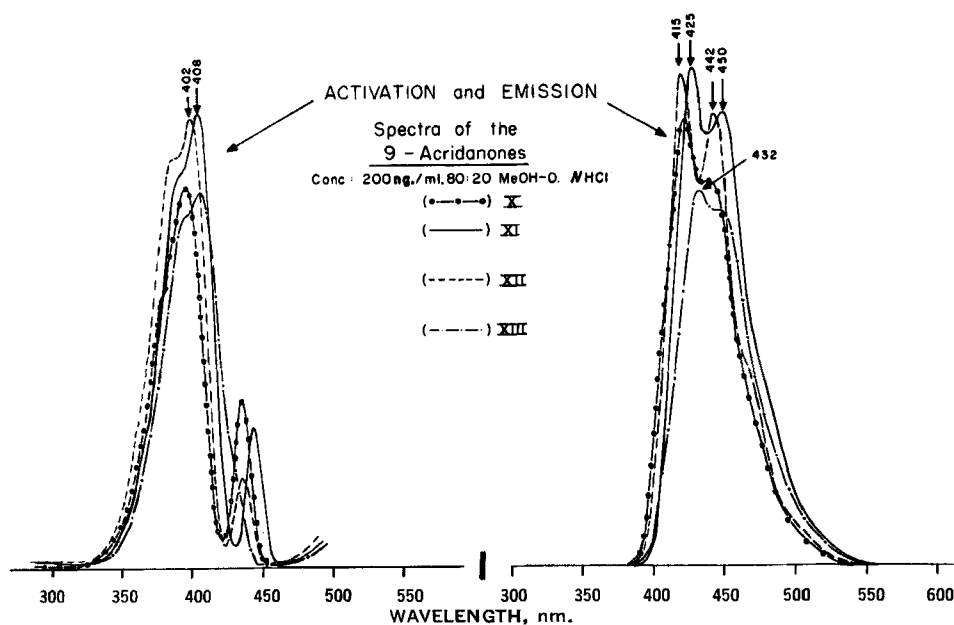

**Figure 1**—Activation/emission spectra of the 9-acridanones.

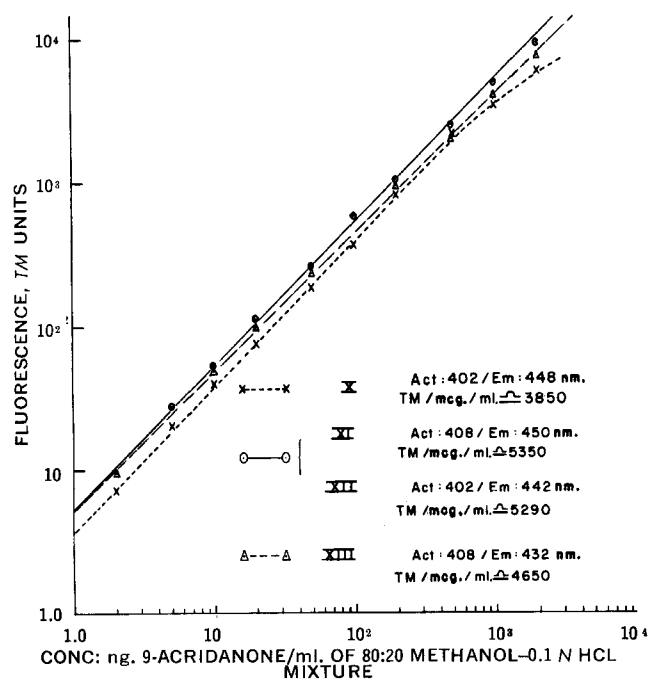

Figure 2—Linear dynamic range of fluorescence versus concentration of the 9-acridanones.

### EXPERIMENTAL

**Preparation of Standard Solutions**—The authentic compounds required as analytical standards are listed in Table I and are of pharmaceutical grade purity (>98%).

**1,4-Benzodiazepin-2-ones**—Weigh out 10 mg. of each of the 1,4-benzodiazepin-2-ones (free base) (I–V) or an equivalent amount of the hydrochloride salt (where applicable) and dissolve in 100 ml. of absolute ethanol in low actinic volumetric flasks. These stock solutions contain 100 mcg./ml. Make suitable serial dilutions of these stock solutions in absolute ethanol to yield working solutions containing 1 mcg./ml., aliquots of which are used for recovery determination from blood or urine.

**9-Acridanones**—Weigh out 10 mg. of each of the 9-acridanones (free base) (X–XIII) or an equivalent amount of the hydrochloride salt (where applicable) and dissolve in 100 ml. of an 80:20 (v/v) mixture of methanol–0.1 N HCl in low actinic volumetric flasks. Heating the solution at 50–55° for 60 min. with intermittent high-speed mixing in an ultrasonic cleaner<sup>2</sup> expedites complete dissolution. These stock solutions contain 100 mcg./ml. Make serial 1:10 dilutions of these solutions in 80:20 methanol–0.1 N HCl to yield working solutions covering a concentration range of 1.0–1000 ng./ml. These solutions are used for the preparation of calibration curves for recovery determination.

**Spectrofluorometric Determination of Flurazepam and Its Major Metabolites (II and III) in Blood or Plasma**—Into a 50-ml. centrifuge tube, add 1.0-ml. aliquots of blood or plasma specimen and 5 ml. of pH 9.0, 1 M borate–KCl–Na<sub>2</sub>CO<sub>3</sub> buffer<sup>3</sup>. Along with the samples, run a 1.0-ml. specimen of control blood or plasma (taken from the subject prior to medication or from a control source) and duplicate 1.0-ml. specimen of control blood or plasma added to mixtures of 100 and 300 ng. each of Compounds I–III, respectively. Extract the samples with two successive 10-ml. portions of diethyl ether<sup>4</sup> on a reciprocating shaker for 10 min., centrifuge for 10 min. at 2100 r.p.m. (preferably at 0–5° in a refrigerated centrifuge), and combine the ether extracts in another 50-ml. tube. (The sensitivity of the assay may be increased, if needed, by using a 4-ml. specimen of blood and 10 ml. of borate buffer. In this event, extract the sample with 2 × 15-ml. portions of ether, combine the ether

extracts in a 50-ml. centrifuge tube, and evaporate the combined ether extract to about 20 ml.)

Add 5 ml. of 4 N HCl to the combined ether extract and back-extract by mechanical shaking for 10 min. Centrifuge the samples and aspirate off the ether. Wash the acid extract with two 10-ml. portions of diethyl ether by shaking for 10 min. on a reciprocating shaker (to remove any lipid material present at the interphase), centrifuge, and aspirate off the ether. Equilibrate the acid extract in a hot water bath to expel any residual ether, stopper the tubes, and hydrolyze the acid extract in a boiling water bath (100°) for 2 hr. to convert quantitatively the benzodiazepin-2-ones to their benzophenones.

After hydrolysis, cool the samples in ice; add 1 drop of bromthymol blue indicator (0.1% in ethanol) and neutralize with 4 N NaOH to a blue-colored end-point. Extract the sample successively with two 10-ml. portions of ether, shaking for 10 min. on a reciprocating shaker per extraction. Centrifuge and combine the ether extracts in a 15-ml. tube by evaporating the ether extracts successively to dryness in a hot water bath (35–40°). To this residue containing the benzophenones (VI–VIII), add 0.5 ml. of dimethylformamide and about 300 mg. of anhydrous K<sub>2</sub>CO<sub>3</sub>. Seal the stopper with a drop of dimethylformamide and place the tubes in a 110° oven. Maintain at 110° for 2 hr. to effect the cyclization of the benzophenones to the 9-acridanones and then cool to room temperature. Add 2.5 ml. of 0.1 N NaOH and 2 ml. of distilled water; mix to dissolve the K<sub>2</sub>CO<sub>3</sub> and dimethylformamide. Add 1 drop of bromthymol blue indicator and extract the sample successively with two 5-ml. portions of ether, shaking for 5 min. on a reciprocating shaker. Centrifuge the samples after each extraction and combine the ether extracts in a 15-ml. centrifuge tube.

Centrifuge the combined ether extracts for 5 min. and carefully remove any aqueous contamination present with a hypodermic syringe fitted with a cannula (B-D-20, 15 cm. in length). Evaporate the ether to dryness in a hot water bath at 35–50° under a stream of nitrogen to remove traces of dimethylformamide. Dry in a vacuum desiccator for 10 min. to remove any moisture and dimethylformamide present and then dissolve the residues in 100 μl. of CHCl<sub>3</sub>, mixing the sample on a vortex high-speed supermixer to ensure uniform solution. Transfer the CHCl<sub>3</sub>; extract onto a 20 × 20-cm. Brinkmann precoated (F<sub>254</sub>) silica gel thin-layer chromatoplate, rinsing the tubes with another 50-μl. portion of CHCl<sub>3</sub> to ensure quantitative transfer. Develop the plate twice for 12–15 cm., ascending in a vapor-saturated tank in 85:15 chloroform–acetone (v/v). This TLC step separates the three 9-acridanones (X, XI, and XII) derived from their respective benzophenones (VI, VII, and VIII) (Scheme I). The plate is examined under shortwave and longwave UV light, and the respective 9-acridanones (X, R<sub>f</sub> 0.15–0.28; XI, R<sub>f</sub> 0.28–0.47; and XII, R<sub>f</sub> 0.42–0.67) are identified as intensely fluorescent blue-green spots by reference to the R<sub>f</sub> values of 1.0-mcg. amounts of the authentic standards run alongside the sample extracts.

The areas on the TLC plate corresponding to the three acridanones are carefully scraped off, transferred into 15-ml. conical centrifuge tubes, and eluted directly with 4 ml. of 80:20 methanol–0.1 N HCl by slurring for 1 min. on a vortex supermixer. The samples are then centrifuged and the supernatant is transferred into a 1-cm. path cell, using a capillary pipet and taking care not to disturb the silica gel at the bottom of the tube.

The fluorescence of the solution containing X is determined at 448 nm., activating at 402 nm., while XI is determined at 450 nm., activating at 408 nm.; that of XII is determined at 442 nm., activating at 402 nm. The fluorescence of XIII (derived from the acidic metabolite in urine) is read at 432 nm., activating at 408 nm. (Figs. 1 and 2).

**Calculations**—The fluorescence readings<sup>5</sup> [transmittance (*T*) × meter multiplier factor (*M*) = *TM*] of all the samples and internal standards are corrected for control (blood or plasma) readings but are uncorrected with respect to activation energy. The amounts of the intact drug (I) and its major blood metabolites (II and III) in

<sup>2</sup> Bronson Automatic Ultrasonic Cleaner, model D-100.

<sup>3</sup> Dissolve 61.8 g. of orthoboric acid (H<sub>3</sub>BO<sub>3</sub>) and 74.6 g. of KCl/l. of distilled water. Add 630 ml. of this solution to 370 ml. of solution containing 106 g. Na<sub>2</sub>CO<sub>3</sub>/l. of distilled water. Shake well and adjust to pH 9.0 with Na<sub>2</sub>CO<sub>3</sub>, if necessary. Store this stock solution at 37°.

<sup>4</sup> Analytical grade reagent, Mallinckrodt.

<sup>5</sup> All fluorescence measurements were made on a Farrand spectrofluorometer equipped with a xenon arc energy source and an RCA IP-28 photomultiplier. The 10-nm. slit arrangement was used at all four positions. The monochromators were corrected for the fundamental Hg lines, but the fluorescence measurements were not corrected for energy and other instrumental artifacts. The instrument sensitivity was adjusted for constant energy for each day of operation, using a reference standard of quinine sulfate (0.1 mcg./ml. in 0.1 N H<sub>2</sub>SO<sub>4</sub>).

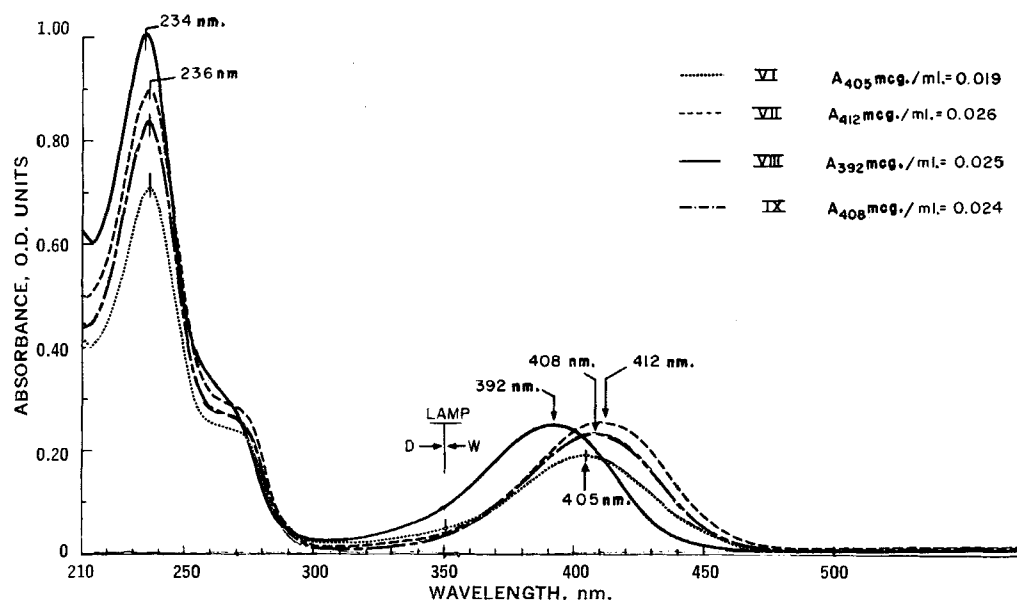

Figure 3—Absorption spectra of the benzophenones.

the unknowns is determined by direct comparison of the corrected fluorescence of the unknowns against that of their respective internal standards.

**Determination of Percent Recovery**—The overall percent recovery of internal standards of I, II, and III, determined as their respective 9-acridanone derivatives, is calculated routinely as a check on analytical precision and accuracy, using the appropriate molecular weight conversion factors for I, II, III, IV, and V of 1.180, 1.216, 1.256, 1.327, and 1.205, respectively.

**Spectrophotometric Determination of Flurazepam and Its Major Metabolites in Urine**—The measurable drug-related compound in the free or directly ether-extractable fraction includes trace amounts of flurazepam (I), with measurable amounts of II, III, and IV. Their concentrations are usually below the sensitivity limit of the absorptiometric assay (<1–2 mcg./ml. of urine); consequently, they have to be quantitated using the spectrofluorometric assay described for blood (Scheme II).

In man the major urinary metabolite is the hydroxyethyl compound (II) present as a conjugate, along with trace amounts of the intact drug, the *N*-desalkyl compound (III), and its 3-hydroxy analog (IV). The urines from treated dogs contain measurable amounts of II, III, and IV mainly in the conjugated form, whereas the major metabolite is the carboxylic acid derivative (V). Since the directly extractable fraction does not yield a significant amount of the dose, it can be combined with the bound fraction and determined as "total" metabolites instead of using separate extraction procedures for the free and conjugated forms. Therefore, after strong acid hydrolysis of the urines to deconjugate the metabolites and hydrolyze them to their respective benzophenones, a differential extraction procedure is employed (Scheme II) which, when combined with TLC, imparts the required specificity of the assay for the respective metabolites. The individual benzophenones are quantitated in methanol by UV/visible absorption spectrophotometry (Fig. 3)<sup>6</sup>.

**Standard Solutions**—In addition to the solutions of the 1,4-benzodiazepin-2-ones required for the fluorometric assay, prepare stock solutions of the *o*-aminobenzophenones (VI–IX) listed in Table I. Weigh out 10 mg. of each of the benzophenones (free base) or an equivalent amount of the hydrochloride salt (where applicable), and prepare the standard solutions as described for the 1,4-benzodiazepin-2-ones in the spectrofluorometric assay.

**Procedure for Urine**—Into a 50-ml. centrifuge tube, add 5 ml. of urine sample and 3.0 ml. of 12 *N* HCl (end normality  $\approx$  4.5). Along with the samples, run a 5-ml. sample of control urine and duplicate 5-ml. samples of control urine containing 25.0 mcg. each of Compounds I–V (0.25 ml. of their respective stock solutions evaporated to dryness under nitrogen) as internal standards. Transfer all the

samples (stoppered) directly into a 100° water bath and hydrolyze for 2 hr. to convert the benzodiazepin-2-ones to their respective benzophenones. Cool the samples to room temperature, and extract with 2  $\times$  15-ml. portions of ether by shaking for 15 min. on a reciprocating shaker. Centrifuge and combine the ether extracts in another 50-ml. centrifuge tube. This is the acidic extract C in Scheme II. Then make the urine specimen strongly alkaline with 5 ml. of 10 *N* NaOH, add 15 ml. of ether, and extract again as before. Centrifuge and combine this alkaline extract (D in Scheme II) with the acidic extract (C). Discard the urine specimen.

Extraction at both acidic and alkaline pH's is necessary for complete recovery of the four benzophenones (VI–IX). However, it does not result *per se* in a quantitative separation of the acidic benzophenone (IX) from the three basic benzophenones (VI–VIII). Therefore, to the combined ether extract (C + D), add 5 ml. of 0.1 *N* NaOH and extract for 10 min. by shaking on a reciprocating shaker. Centrifuge, transfer the supernatant ether (which now contains only the basic benzophenones) into another 50-ml. tube, and evaporate to dryness. Back-wash the NaOH phase, containing only IX, with 10 ml. of ether, shaking for 10 min. Centrifuge and combine this ether wash with the residue of ether extract (C + D); evaporate again to dryness. Process the ether-washed NaOH solution separately for IX. Dissolve the ether residue (C + D) in 100  $\mu$ l. of acetone, transfer quantitatively onto a 20  $\times$  20-cm. Brinkmann (F<sub>254</sub>) silica gel chromatoplate, and develop the plate in a vapor-saturated chamber to 12–15 cm., ascending in benzene-methanol-glacial acetic acid (90:10:10 v/v). The three benzophenones (VI,  $R_f \approx$  0.3; VII,  $R_f \approx$  0.5; VIII,  $R_f \approx$  0.7) produced by acid hydrolysis of their respective benzodiazepin-2-ones (Scheme I) are identified either under shortwave UV light as dark absorbing areas or under visible light as intensely yellow spots by reference to the  $R_f$  of 25-mcg. amounts of the authentic benzophenone standards run alongside the sample extracts. The plate may be redeveloped in the same solvent system to obtain greater resolution if needed.

The ether-washed NaOH solution containing the acidic benzophenone (IX) is made strongly acidic with 1 ml. of 4 *N* HCl and extracted with two 15-ml. portions of ether by shaking for 10 min. Centrifuged, the ether supernatants are combined and evaporated to dryness. Discard the NaOH solutions at this stage. Dissolve the ether residues in 100  $\mu$ l. of methanol, transfer quantitatively onto a 20  $\times$  20-cm. Brinkmann (F<sub>254</sub>) chromatoplate, and develop in the same solvent system as described for the basic benzophenones. The acidic benzophenone (IX,  $R_f \approx$  0.47) is identified by reference to the  $R_f$  of 25 mcg. of the authentic standard run alongside the sample extracts. Besides IX, the acidic fraction contains a considerable amount of impurities, probably phenolic and indolic acids, which contribute to high blank values in spectrophotometric analysis. These impurities can be adequately separated from IX by TLC due to their higher  $R_f$  values. Consequently, it is advantageous to separate the basic benzophenones first from the acidic fraction by selective extraction prior to TLC separation.

<sup>6</sup> The UV absorption spectra were obtained using a Coleman-Hitachi EPS-3 double-beam ratio recording spectrophotometer.

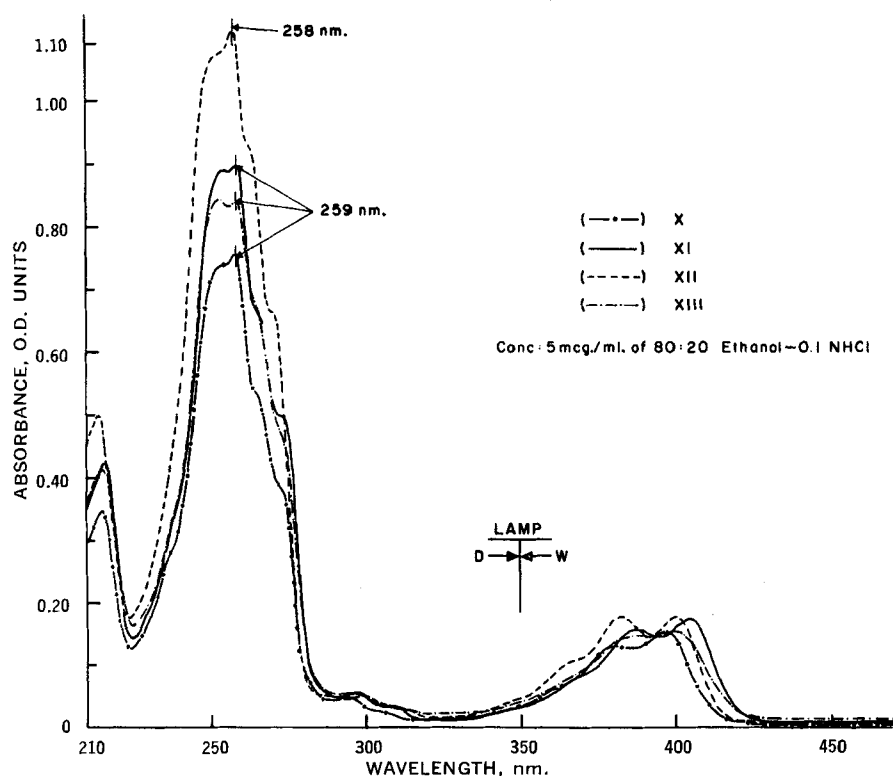

Figure 4—Absorption spectra of the 9-acridanones.

The silica gels from the respective benzophenone areas are carefully scraped off into separate 15-ml. centrifuge tubes, eluted with 4 ml. of methanol by slurring for 1 min. on a vortex high-speed supermixer, and centrifuged. The supernatant is decanted into a 1-cm. path cell, and the absorbance is determined at their respective maxima (VI at 405 nm., VII at 412 nm., VIII at 392 nm., and IX at 408 nm.) (Fig. 3).

The amount of each compound (I-V) in the unknowns is calculated by direct comparison to the absorbance values of their respective internal standards.

**Determination of Percent Recovery**—The overall recovery of the internal standards is determined by comparing the absorptivity of the recovered internal standards measured as the benzophenones directly to that of an external standard of the respective authentic benzophenones using the appropriate molecular weight conversion factors for Compounds I, II, III, IV, and V of 1.112, 1.132, 1.156, 1.220, and 1.127, respectively.

If the concentration of the benzodiazepin-2-ones is below the limit of detectability of the absorptiometric assay (<1-2 mcg. of compound/ml.), the limit of detection can be extended by employing the fluorometric assay. A 2-ml. aliquot of the methanol solution (from the spectrophotometric assay) of the control, the unknowns, and a 0.01-ml. aliquot of the internal standards (containing  $\approx$  0.625 mcg. of compound) are evaporated to dryness; the benzophenone is cyclized in dimethylformamide/ $K_2CO_3$  to the 9-acridanone as described in the blood assay. However, when extracting the acidic acridanone (XIII), the extraction procedure is modified. For the acidic acridanone, slowly add 2.5 ml. of 4 N HCl, mix (end pH  $\sim$  1.0-2.0), and extract the sample successively with 3  $\times$  5-ml. portions of ether, which are combined and evaporated to dryness. The TLC separation of these 9-acridanone derivatives is not necessary. The final ether residues containing the respective 9-acridanones are dissolved in 4 ml. of 80:20 methanol-0.1 N HCl and quantitated fluorometrically as described.

## RESULTS AND DISCUSSION

Several analytical parameters were investigated during the development of a suitable assay procedure for flurazepam and its major metabolites. The UV absorption spectrum of the pure compound (I) in 0.1 N HCl showed a maximum at 240 nm., with an absorptivity ( $A/mcg./ml.$ ) of 0.070. In 0.1 N NaOH, the UV maximum was at 234 nm., with an absorptivity of 0.076. The potential sensitivity limit was of the order of 2-3 mcg./ml. of sample, but its

usefulness as an absorptiometric assay was limited due to high blank values obtained from the biological specimen.

A new synthesis of 9-acridanones from *o*-amino-2'-fluorobenzophenones was reported by Fryer *et al.* (8). According to these investigators, the fluorine was sufficiently activated by the *ortho*-carbonyl group to react readily with the aromatic amine, thus undergoing internal nucleophilic exchange to give high yields of the corresponding 9-acridanones. This procedure was successfully scaled down to enable the preparation of these derivatives in high yield in the submicrogram range.

The major metabolites of flurazepam (I) are the hydroxyethyl analog (II) and the *N*-dealkylated analog (III) present in measurable amounts in the blood. The 3-hydroxy-*N*-dealkylated analog (IV) is present in the urine mainly as the glucuronide conjugate, as is the hydroxyethyl analog (II). The carboxylic acid (V) is found mainly in the dog and to lesser amounts in man (4). All these compounds undergo strong acid hydrolysis to their respective benzophenones, which can then be cyclized to their respective 9-acridanones as indicated in Scheme I. The same sequence of reactions also takes place under strongly alkaline conditions but is not analytically useful due to the formation of several undesirable by-products which greatly reduces the overall yield of the 9-acridanones.

The spectrofluorometric assay initially developed for the determination of intact I and its metabolites in blood was modified, using differential extraction procedures for the determinations of the metabolites (II-V) in urine. Several TLC systems (Table II) were employed to separate the different metabolites either as their respective benzophenones or as their 9-acridanones prior to quantitation, thus ensuring the specificity of the assay for each compound (Scheme II). The high fluorescence intensity of each of the 9-acridanones in 80:20 methanol-0.1 N HCl was sufficient for the determination of about 3.0-5.0 ng. of 9-acridanone/ml. of final solution. This property was used by Sawicki *et al.* (9) in the determination of trace amounts of 9-acridanone (0.4 ng./m<sup>3</sup> of air) as an atmospheric pollutant. The specific fluorescence intensity of each compound, determined at its respective activation/emission maxima<sup>6</sup>, was of about the same order of magnitude, with  $TM/mcg./ml.$  values of 3850, 5350, 5290, and 4650 for X, XI, XII, and XIII, respectively.

The absorption spectra of the 9-acridanones in 80:20 methanol-0.1 N HCl (Fig. 4) show great similarity in their spectral characteristics, despite the presence of a different alkyl side chain in each compound. The main absorption bands due to the acridanone ring

**Table II**—TLC Systems for the Separation of the 1,4-Benzodiazepin-2-ones, Their Respective Benzophenones, and 9-Acridanones Using Brinkmann (F<sub>264</sub>) Silica Gel G Plates in Vapor-Saturated Chambers

Compound	<i>R<sub>f</sub></i> in Solvent System <sup>a</sup>					Detection by <sup>c</sup>		
	1 <sup>b</sup>	2	3 <sup>b</sup>	4a <sup>b</sup>	4b <sup>b</sup>	Visible	Shortwave UV	Longwave UV
1,4-Benzodiazepin-2-ones:								
I	0.14	0.38	0.26	0.00	0.05	—	Abs.	Abs.
II	0.23	0.52	0.47	0.15	0.25	—	Abs.	Abs.
III	0.40	0.60	0.50	0.25	0.42	—	Abs.	Abs.
IV	0.20	0.42	0.42	0.15	0.50	—	Abs.	Abs.
V	0.00	0.00	0.34	0.00	0.00	—	Abs.	Abs.
Benzophenones:								
VI	0.36	0.57	0.30	0.05	0.12	Yellow	Abs.	Abs.
VII	0.40	0.64	0.50	0.35	0.58	Yellow	Abs.	Abs.
VIII	0.56	0.72	0.70	0.60	0.83	Yellow	Abs.	Abs.
IX	0.00	0.00	0.47	0.00	0.00	Yellow	Abs.	Abs.
9-Acridanones:								
X	0.16	0.45	0.27	0.15	0.28	—	Blue/fluor.	Fluor.
XI	0.27	0.52	0.45	0.28	0.47	—	Blue/fluor.	Fluor.
XII	0.40	0.64	0.30	0.42	0.67	—	Blue/fluor.	Fluor.
XIII	0.00	0.00	0.40	0.00	0.00	Faint yellow	Blue/fluor.	Fluor.

<sup>a</sup> Developing solvent systems were: 1, 100:0.5 ethyl acetate-NH<sub>4</sub>OH; 2, 100:10:0.3 ethyl acetate-ethanol-NH<sub>4</sub>OH; 3, 90:10:10 benzene-MeOH-HAc; and 4, 85:15 chloroform-acetone (a, first development, and b, second development). <sup>b</sup> These systems gave the best overall resolution. <sup>c</sup> Abs. = absorption. Fluor. = fluorescence.

appears to be unaffected by the alkyl substituents. A strong UV band ( $\lambda_{\text{max.}} = 258\text{--}260\text{ nm.}$ ) offers good potential for absorptometric analysis. The absorption in the visible region reveals maxima at 380, 390, 400, and 405 nm. due to the yellow color of these compounds. These bands also correspond to the wavelengths of activation selected for the fluorometric assay. The spectral resolution of the monochromators of the Farrand spectrofluorometer used in this study is sufficiently narrow that these activation bands, which differ from the fluorescence emission bands selected by 30 nm. or more, can be used without interference from Raman scatter. Although the strong UV absorption bands at 258–260 nm. would theoretically be superior for purposes of activation, the low energy output of the xenon arc continuum in this region greatly reduces the intensity of fluorescence emission (and, therefore, sensitivity) when the samples are activated at 258–260 nm. However, with a mercury vapor lamp as an energy source, these UV bands would be preferred for activation of the 9-acridanones.

The fluorescence intensity of each compound was also linear with concentration in the range of 2.5 to  $2.0 \times 10^3$  ng./ml. of final solution (Fig. 2). The recovery of I and II is linear and reproducible in the concentration range of 10 ng.–10 mcg. of compound/ml. of blood or urine. The sensitivity limits of the assay are of the order of 3.0–10.0 ng. of compound/ml. of blood or urine, using a 4-ml. specimen per assay and a sample-blank (TM) ratio of 2:1 as the limit of detectability.

The overall recovery of the spectrofluorometric assay for flurazepam and its metabolites is based on four separate steps: extraction, hydrolysis, cyclization, and elution from the TLC plate prior to fluorometric determination, and it represents the product of quantitative extraction from blood or urine >95% followed by a >95% hydrolysis to the benzophenone, a >85% cyclization to the 9-acridanone, and a >90% recovery from the TLC plate. Therefore, the expected overall recovery from blood and urine is of the order of 70%. Optimal reaction conditions for each step were established initially for flurazepam (I) and the hydroxyethyl compound (II) and

applied either as such or with minor modifications for the other compounds. The actual recoveries obtained, however, fell short of the expected value because of interference incurred in the cyclization and TLC separation steps due to the presence of impurities extracted from blood or urine.

The overall recovery of flurazepam (I) and its major metabolite (II) obtained from blood was  $50 \pm 9.0$  and  $71 \pm 4.0\%$ , respectively, while that of the metabolite (II) from urine was  $64 \pm 5.0\%$ . The recovery of II is in acceptable agreement with the theoretically expected value. The poor overall recovery of flurazepam (I) from blood appears to be due to a decrease in the efficiency of the cyclization reaction in the presence of blood-extracted impurities as compared against a direct reaction of the pure benzophenone to the 9-acridanone where the efficiency was >75%. The overall recovery of the other three metabolites (III–V) determined by the present procedure was somewhat less than that of II (Table II). However, the recoveries were sufficiently reproducible to permit their quantitation in biological specimens.

The identification of the major urinary metabolites of flurazepam in man and in the dog using <sup>14</sup>C-labeled flurazepam·2HCl was reported by Schwartz and Postma (4). The major urinary metabolites in man and in the dog were II and V, respectively, and were assayed as their respective benzophenones by spectrophotometry since their concentrations were sufficiently high (>1–2 mcg./ml.) for their quantitation by the less sensitive but simpler assay. The absorption spectra (Fig. 3) indicated specific absorbance (A/mcg./ml.) values and resulting sensitivity limits of detection (1–2 mcg./ml. of final solution) of the same order of magnitude for each benzophenone, measured at its respective maximum in the visible region. The absorbance of each compound was linear with concentration in the range of 1.0–50.0 mcg. of benzophenone/ml. of final solution (methanol). Although the absorbance in the UV at 234–236 nm. was greater than that in the visible region and provided greater potential sensitivity, the high blank values obtained in this region of the UV from biological extracts read in methanol offset this advantage. The

**Table III**—Determination of Percent Recovery of Flurazepam and Its Metabolites in the Separate Steps Involved in the Overall Spectrofluorometric and Spectrophotometric Assays

Parent Compound	Spectrofluorometric Assay in Blood and Urine				Spectrophotometric Assay in Urine		
	Hydrolysis to Benzophenone	Cyclization to 9-Acridanone	Elution from Silica Gel	Overall Recovery Expected	Actual Recovery from Blood	Actual Recovery from Urine	Actual Recovery from Urine
I	93 ± 2.0	74 ± 4.0	98 ± 2.0	67	50 ± 9.0	60 ± 4.0	90 ± 5.0
II	95 ± 5.0	90 ± 6.0	94 ± 4.0	80	70 ± 4.0	65 ± 4.0	83 ± 2.0
III	95 ± 5.0	63 ± 3.0	93 ± 4.0	56	38 ± 7.0	60 ± 6.0	70 ± 15.0
IV	83 ± 5.0	63 ± 3.0	93 ± 4.0	49	N.D. <sup>a</sup>	35 ± 5.0	35 ± 4.0
V	86 ± 4.0	74 ± 3.0	98 ± 2.0	63	N.D.	45 ± 5.0	78 ± 8.0

<sup>a</sup> N.D. = not determined as such in blood.

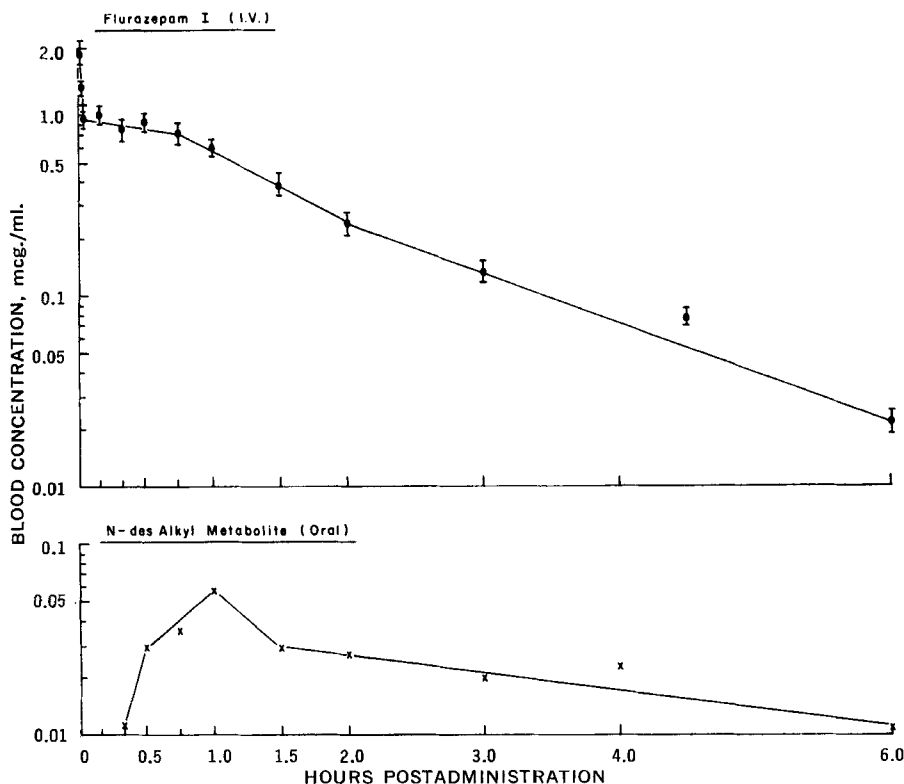

Figure 5—Blood level fall-off curves of flurazepam and its major metabolites in a dog following the administration of a 5-mg./kg. dose by (top) intravenous and (bottom) oral routes.

overall recovery from urine of added internal standards of II, IV, and V determined by the absorptiometric assay was of the order of 85, 35, and 78%, respectively (Table III). The sensitivity limits of the absorptiometric assay can be extended by cyclization of the respective benzophenone to its 9-acridanone derivative, which is then quantitated by the more sensitive fluorometric assay (Scheme II).

**Application of Methods in Biological Specimens—Determination of Blood and Urine Levels in the Dog**—Blood level fall-off curves of flurazepam and its major metabolites were determined in a dog following intravenous and oral administrations of 5-mg./kg. doses (50 mg. of flurazepam·2HCl) given 2 weeks apart. Following intravenous administration, only the intact drug (I) was seen in the blood (Fig. 5) over an 8-hr. period. No measurable amounts of metabolites II–V were seen. Following oral administration, however, no measurable levels of flurazepam (I) were noted. The only measurable compound in the blood was the *N*-desalkyl metabolite (III), which was present in low amounts and measurable up to 6 hr. postdosing. The data indicate that the drug was rapidly and extensively metabolized.

The urinary excretion data following both intravenous and oral doses are given in Table IV. Following intravenous administration, approximately 4.58% of the dose was recovered as the intact drug and 10.9% of the dose was recovered as the acidic compound (V) (the major urinary metabolite in the dog) over a 24-hr. period. The other metabolites (II–IV) accounted for only 1.88% of the dose in the same period. The 24–48-hr. period yielded only 0.44% of the dose in

approximately equal amounts of II, IV, and V. Following oral administration, the acidic metabolite (V) accounted for 10.1% of the dose in the 0–24-hr. period. The other metabolites accounted for a total of 2.54% of the dose over the same time period. The 24–48-hr. period yielded negligible amounts (0.7%) of the dose, mainly as V. The total amount of the administered dose recovered in the 0–48-hr. excretion period following intravenous and oral administrations was 17.8 and 13.34%, respectively.

These experiments indicate that the rapid elimination of flurazepam from the blood following intravenous administration, the absence of measurable intact drug in the blood following oral administration, and the excretion of several metabolites in the urine are due to tissue distribution and rapid biotransformation of the drug.

The presence of the hydroxyethyl compound (II), the *N*-desalkyl compound (III), the *N*-desalkyl-3-hydroxy compound (IV), and the *N*-1-acetic acid metabolite (V) suggest that two pathways of biotransformation are possible, arising from a common intermediate such as an aldehyde (Scheme III) as proposed by Schwartz and Postma (4).

According to these authors, II is the major metabolite in man whereas V is the major metabolite in the dog. Further metabolic studies for the elucidation of the biotransformation of II were conducted in a dog following the oral administration of a 20-mg./kg.

Table IV—Urinary Excretion Data on Flurazepam and Its Major Metabolites in a Dog following Intravenous and Oral Administration<sup>a</sup>

Compound Excreted <sup>b</sup> as Percent of Dose	Route of Administration	
	Intra-venous	Oral
I	4.58	0.37
II	0.37	0.29
III	0.11	0.04
IV	1.40	1.84
V	10.90	10.10
Total percent of dose recovered <sup>c</sup>	17.36	12.64

<sup>a</sup> Dose: 50 mg. flurazepam·2HCl = 42.10 mg. of free base (5 mg./kg.). Excretion period: 0–24 hr. postdosing. <sup>b</sup> Calculated as the flurazepam equivalent. <sup>c</sup> As “free” (directly extractable) and “bound” (conjugated) fractions.

Table V—Urinary Excretion Data on the Hydroxyethyl Metabolite (II) in a Dog following Administration of a Single Oral 20-mg./kg. Dose of the Authentic Compound as the Hydrochloride Salt versus the Free Base<sup>a</sup>

Hours Postdosing	Hydrochloride Salt 270 mg.		Free Base 256 mg.	
	Percent of Dose Recovered in Urine <sup>b</sup>			
	Free	Bound	Free	Bound
0–24	0.15	11.00	1.20	9.70
24–48	0.22	1.40	0.13	1.10
48–72	0.01	0.44	0.02	0.24
	0.38	12.84	1.35	11.04
Percent total dose recovered	13.23		12.39	

<sup>a</sup> Dose: 20 mg./kg. = 256 mg. of free base. <sup>b</sup> Free = directly extractable II. Bound = glucuronide/sulfate conjugate of II.



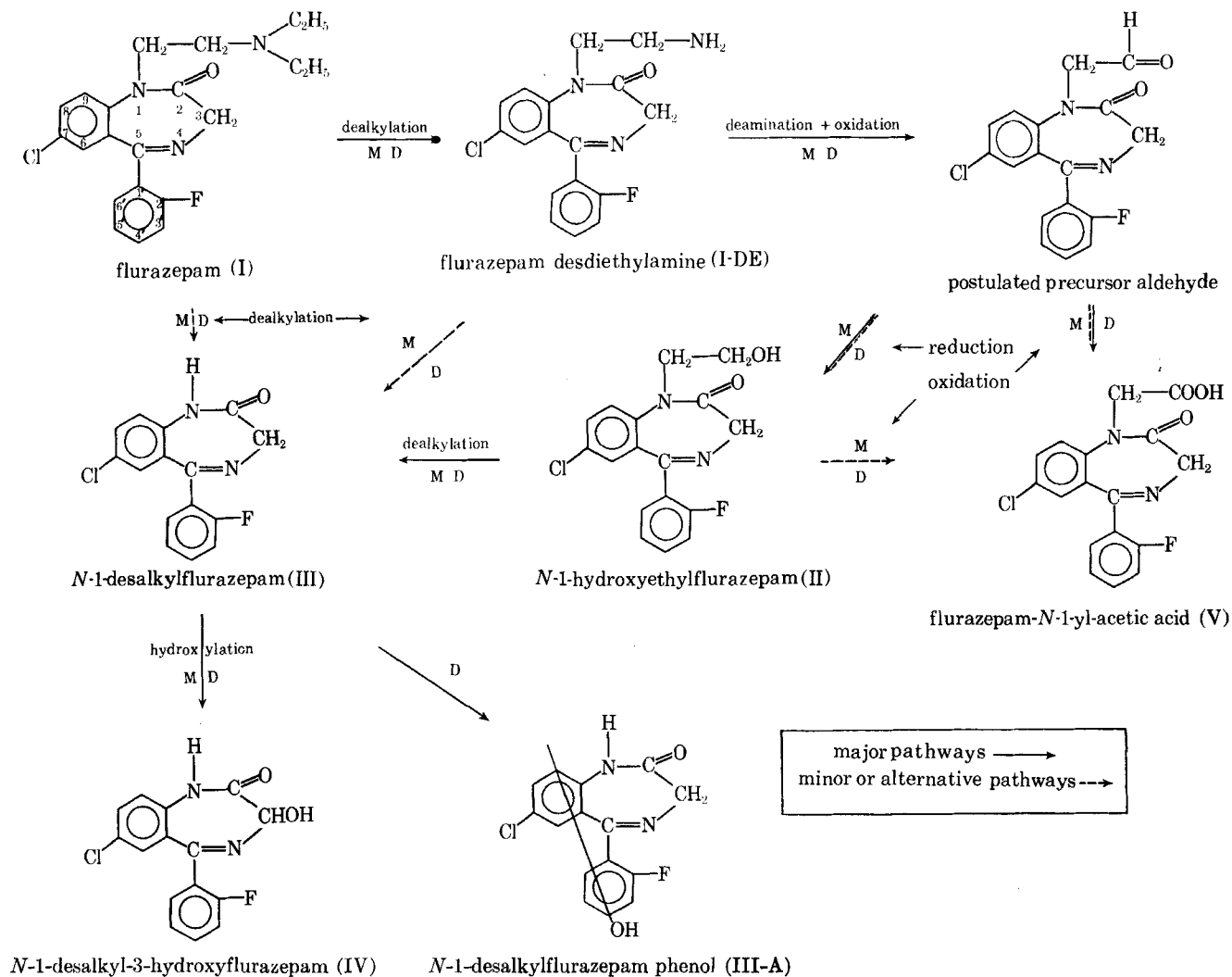

N-1-desalkyl-3-hydroxyflurazepam (IV) N-1-desalkylflurazepam phenol (III-A)  
 Scheme III—Postulated metabolic pathways of flurazepam in man (M) and in dog (D)

dose of II as the hydrochloride salt *versus* the free base. The two forms of the compound were administered 7 days apart in a gelatin capsule. Specimens of whole blood and urine were collected over a 72-hr. period. The blood level fall-off curves (Fig. 6) showed that both forms were rapidly absorbed and produced a blood level peak between 30 and 60 min. The areas under the curves in the 0-24-hr. period were found to be equivalent (base: HCl = 4.99/4.55 = 1.097).

The urinary excretion data on free and conjugated II are given in Table V. The data show that the major portion of the administered dose that was recoverable was excreted in the 0-24-hr. period. The

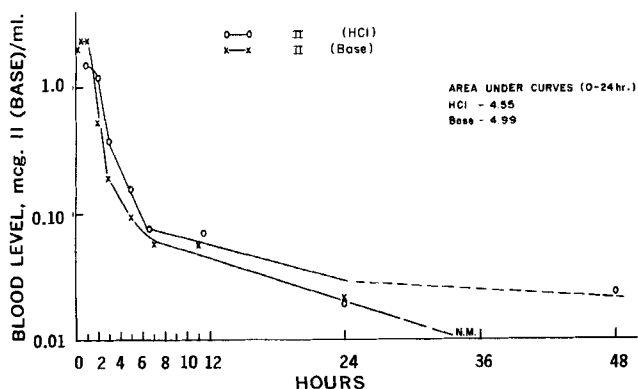

Figure 6—Blood level fall-off curves of II in a dog following the oral administration of a single 20-mg./kg. dose of the hydrochloride salt versus the free base.

major excretion product recovered was the glucuronide and/or sulfate conjugate of II, accounting for 9.7-11% of the dose recovered in the first 24 hr. The amount of free II excreted in the same period was 0.15% of the dose from the hydrochloride salt and 1.20% of the dose from the free base. Approximately equal amounts of II (*i.e.*, free and conjugated), 13.23% from the hydrochloride salt and 12.3% from the free base, were recovered in the 0-72-hr. period. The low percentage of the dose recovered again indicates either extensive biotransformation and/or alternate routes of excretion.

Due to the low recovery of the administered dose as free II in the treated dog urines, the samples were reanalyzed by the differential spectrophotometric assay for the quantitation of IV and V, the other known metabolites of flurazepam. The data in Table VI show that approximately 8% of the dose was recovered as IV and V, respectively. The total amount of the dose administered either as the free base or the hydrochloride salt of II recovered in the 0-24-hr. period

Table VI—Urinary Excretion Data on the Metabolites of II in a Dog following the Oral Administration of a 20-mg./kg. Dose of the Free Base (256 mg.)

Excretion Period	Metabolite Measured	Milli-grams of Metabolite Recovered	Calculated as II Equivalent	Percent of Dose Excreted
0-24 hr.	IV	19.0	21.0	8.16
0-24 hr.	V	22.0	21.8	8.50
Total recovered in 0-24 hr.:		41.0	42.8	16.66

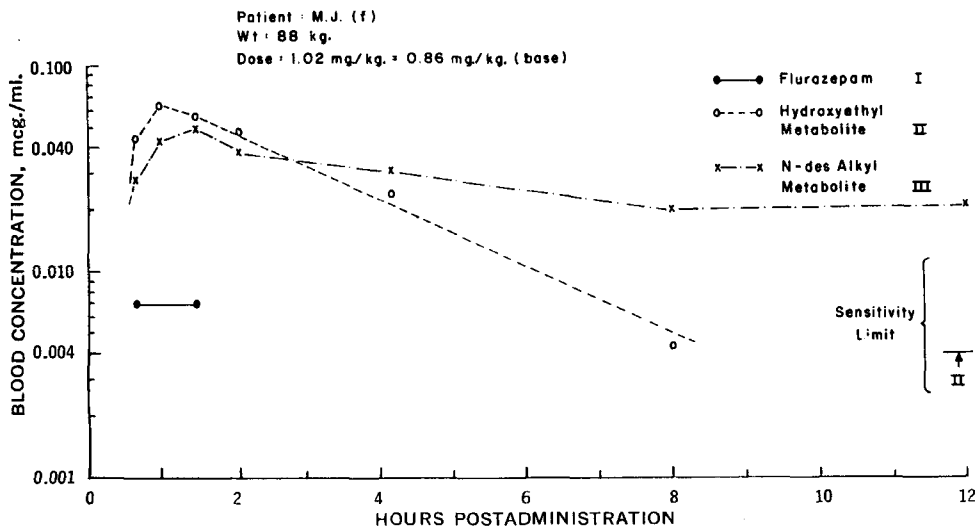

Figure 7—Blood level fall-off curves of flurazepam and its major biotransformation products in man following a single 90-mg. oral dose of flurazepam·2HCl.

was 27.6%. These experiments also indicate that the preferred metabolic pathway of flurazepam in the dog leads to the formation of the acidic metabolite (V) and appears to be *via* an intermediate such as an aldehyde rather than *via* the hydroxyethyl compound (II).

**Determination of Blood and Urine Levels in Man**—Blood level fall-off curves and the urinary excretion of flurazepam and its major metabolites were determined in two human subjects: in Patient M. J. (f) following a single oral 90-mg. dose of flurazepam·2HCl (3 × 30-mg. capsules) and in Patient H. R. (m) following two oral 90-mg. doses of the drug given 21 days apart.

The blood level curves in Patient M.J. (Fig. 7) show data points at 40 and 90 min., at which measurable levels of flurazepam were seen. The major blood components in this subject were: (a) the hydroxyethyl metabolite (II), which reached a maximum concentration of 0.064 mcg./ml. at 1 hr. and declined over the next 7 hr., with a half-life of about 2 hr.; and (b) the *N*-desalkyl metabolite (III), which reached a peak level of 0.049 mcg./ml. at 1.5 hr. and appeared to plateau thereafter.

The blood level curves in Patient H. R. (Fig. 8A) following the first 90-mg. dose showed low but measurable amounts of flurazepam, which reached a maximum of 0.02 mcg./ml. at 1 hr. and were

detectable up to 12 hr. The metabolite (II), on the other hand, showed a peak concentration of 0.072 mcg./ml. at 40 min. and declined over the next 11 hr., with a half-life of about 2 hr. The *N*-desalkyl metabolite (III) showed a peak level of 0.056 mcg./ml. at 1 hr. and after 2 hr. declined with an apparent half-life of about 19 hr.

Upon administration of the second 90-mg. dose to the same subject (H. R.) 21 days later, the blood levels of flurazepam (I) (Fig. 8B) again reached a peak at 1 hr. of about 0.012 mcg./ml. and declined rapidly to the detectable limit at 4 hr. The blood level curves of metabolites II and III almost paralleled those obtained following the first dose.

The urinary excretion data on flurazepam and its metabolites in man are summarized in Table VII. In both subjects, the amount of intact drug and the major blood metabolites (II and III) excreted in the free or directly extractable fraction was very small (1% or less). The major urinary metabolite was the hydroxyethyl compound (II), which was excreted mainly in the bound form as a glucuronide/sulfate conjugate, accounting for more than 40% of the administered dose in the 0–24-hr. excretion period and about 4% of the dose in the 24–48-hr. period. Trace amounts of metabolites IV and V were also seen, collectively accounting for about 4% of the

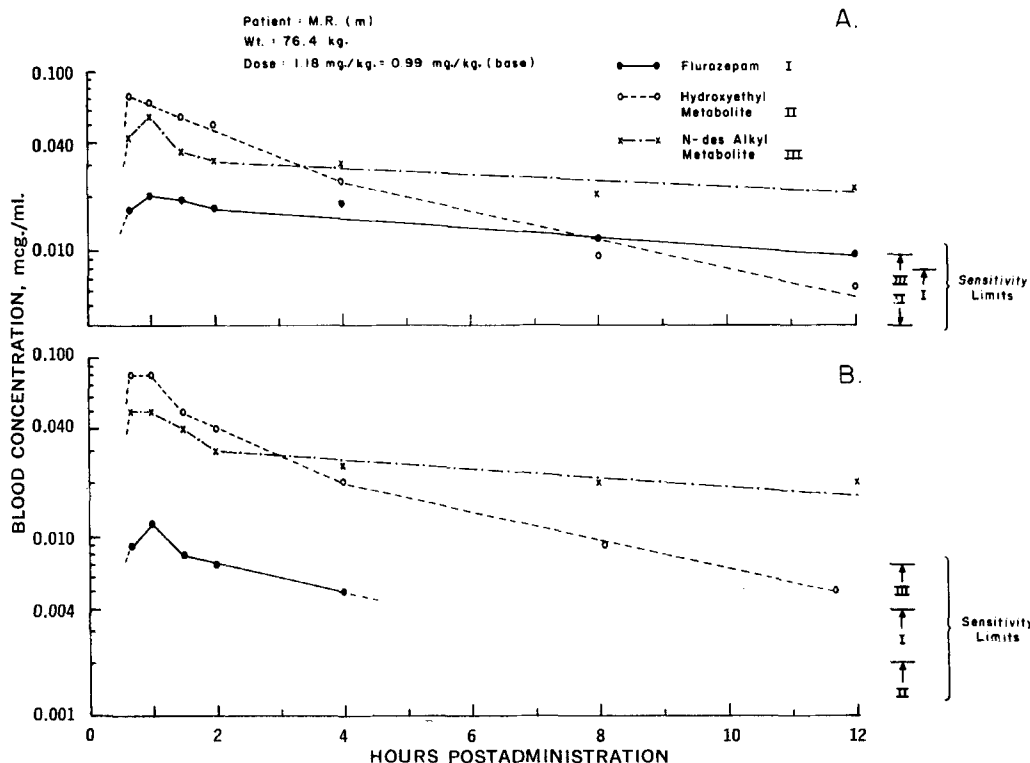

Figure 8—Blood level fall-off curves of flurazepam and its major biotransformation products in man following single 90-mg. oral doses of flurazepam·2HCl administered 21 days apart.

**Table VII—Urinary Excretion Data on Flurazepam and Its Major Metabolites in Humans following Administration of Single Oral 90-mg. (3 × 30-mg.) Doses of Flurazepam·2HCl**

Hours	Form Excreted	Compound Measured	Micrograms per Milliliter	Total, mg.	Milligrams Equivalent as Flurazepam	Percent of Dose Excreted	Total Recovered as Free and Bound	Percent Total Dose Recovered
A: Subject M. J. (f) (Dose: 90 mg. Salt = 75.76 mg. of Flurazepam Free Base)								
0-8	Free <sup>a</sup>	I	0.14	0.08	0.08	0.10	0.89	
		II	0.15	0.09	0.10	0.13		
		III	0.65	0.38	0.50	0.66		
	Bound <sup>b</sup>	II	45.00 <sup>c</sup>	26.30	30.60	40.40		
		IV	0.96	0.56	0.70	0.93		
	V	1.20	0.67	0.75	1.00	42.33	43.22	
8-24	Free	I	0.03	0.05	0.05	0.08	0.41	
		II	0.02	0.04	0.04	0.05		
		III	0.10	0.16	0.21	0.28		
	Bound	II	2.75	4.10	4.80	6.30		
		IV	0.10	0.15	0.19	0.25		
	V	0.09	0.14	0.16	0.21	6.76	7.17	
24-48	Free	I	0.03	0.08	0.08	0.10	0.83	
		II	0.02	0.05	0.05	0.07		
		III	0.14	0.38	0.50	0.66		
	Bound	II	1.00	2.90	3.40	4.40		
		IV	0.06	0.16	0.20	0.26		
	V	0.06	0.16	0.18	0.24	4.90	5.73	
<u>56.12</u>								
B: Subject H. R. (m) (Dose I: 90 mg. Salt = 75.76 mg. Free Base)								
0-24	Free	I	0.14	0.16	0.16	0.21	1.63	
		II	0.07	0.08	0.10	0.12		
		III	0.63	0.72	1.00	1.30		
	Bound	II	24.20 <sup>c</sup>	27.80	32.40	42.80		
		IV	0.64	0.74	0.97	1.26		
	V	0.26	0.30	0.34	0.45	44.51	46.14	
24-48	Free	I	0.05	0.09	0.09	0.12	0.86	
		II	0.01	0.02	0.03	0.04		
		III	0.22	0.40	0.50	0.70		
	Bound	II	1.41	2.54	2.96	3.91		
		IV	0.07	0.12	0.16	0.21		
	V	0.05	0.09	0.10	0.14	4.26	5.12	
<u>51.26</u>								
Determination of Only the Total Major Urinary Metabolite (II) (Free and Bound) by Spectrophotometry								
C: Subject H. R. (m) (Dose II: 90 mg. Salt = 75.76 mg. of Free Base)								
0-8	Total <sup>d</sup>	II	74.1	14.8	17.3	22.8		
8-24	Total	II	15.4	8.5	9.9	13.0		
24-48	Total	II	n.m. <sup>e</sup>	—	—	—		
<u>35.8</u>								

<sup>a</sup> Free = directly extractable. <sup>b</sup> Bound = conjugated. <sup>c</sup> Determined by spectrophotometry, all other data by spectrofluorometry. <sup>d</sup> Total = free and conjugated forms. <sup>e</sup> n.m. = not measurable < 1-2 mcg./ml.

dose in the 0-48-hr. period. When the same dose was repeated in the same subject (H. R.) after a wash-out period of 21 days, the 0-24-hr. urine specimen yielded 36% of the administered dose as the hydroxyethyl metabolite (II) in both free and conjugated forms. The total urinary excretion of flurazepam and its metabolites in both subjects in the 0-48-hr. period following the oral administration of 90-mg. doses of flurazepam·2HCl appears to be consistent and reproducible, with a total of 56% of the dose eliminated by Patient M. J. (f) and 51% of the dose eliminated by Patient H. R. (m).

The administration of flurazepam by either intravenous or oral routes in the dog and orally in man results in rapid and extensive biotransformation prior to elimination. According to Schwartz and Postma (4), flurazepam (I) was metabolized by successive *N*-dealkylation of the side chain (Scheme III), which appeared to be the preferred pathway to direct hydroxylation of the benzodiazepine ring. In the dog, the major urinary metabolite was the acidic compound V, while the hydroxyethyl compound II was a minor metabolite. In man, the converse was true; II was the major blood and urinary metabolite and V was a minor metabolite seen only in the urine. The presence of small amounts of III and IV in the urine of both species lends support to the postulation of the existence of a common precursor (metabolite), such as an aldehyde produced by *N*-dealkylation and oxidative deamination of the terminal (—N<) in the alkyl side chain of flurazepam. In the dog, oxidation of the aldehyde as the

preferred pathway would result in the excretion of V as the major metabolite; in man, reduction of the aldehyde to an alcohol would result in the excretion of II as the major metabolite. The mono-desethyl and desdiethylamine (I-DE) metabolites detected in trace amounts in both man and dog and the phenolic analog (III-A) (2) seen only in the dog, as reported by Schwartz and Postma (4), were detected in this study but were not quantitated.

The results of this study, using flurazepam·2HCl in the dog as a pure chemical and in man as the pharmaceutical formulation, are in agreement with the findings of the authors (4) who used <sup>14</sup>C-labeled flurazepam·2HCl exclusively.

#### REFERENCES

- (1) L. H. Sternbach, G. A. Archer, J. V. Earley, R. I. Fryer, E. Reeder, N. Wasyliv, L. O. Randall, and R. Banziger, *J. Med. Chem.*, **8**, 815(1965).
- (2) M. A. Schwartz, F. M. Vane, and E. Postma, *ibid.*, **11**, 770 (1968).
- (3) J. V. Earley, R. I. Fryer, D. Winter, and L. H. Sternbach, *ibid.*, **11**, 774(1968).
- (4) M. A. Schwartz and E. Postma, *J. Pharm. Sci.*, **59**, 1800(1970).

(5) R. I. Fryer and J. Earley, unpublished data, Dept. Chemical Research, Hoffmann-La Roche Inc., Nutley, N. J., 1968.

(6) L. H. Sternbach, R. I. Fryer, W. Metlesics, G. Sach, and A. Stempel, *J. Org. Chem.*, **27**, 3781(1962).

(7) L. H. Sternbach, R. I. Fryer, W. Metlesics, E. Reeder, G. Sach, G. Saucy, and A. Stempel, *ibid.*, **27**, 3788(1962).

(8) R. I. Fryer, J. Earley, and L. H. Sternbach, *J. Chem. Soc.*, **1963**, 4979.

(9) E. Sawicki, T. W. Stanley, and W. C. Elbert, *Talanta*, **14**, 431 (1967).

## ACKNOWLEDGMENTS AND ADDRESSES

Received September 8, 1970, from the Department of Biochemistry and Drug Metabolism, Hoffmann-La Roche Inc., Nutley, NJ 07110  
Accepted for publication May 6, 1971.

The authors are indebted to Dr. R. I. Fryer and Mr. J. Earley for the syntheses of the authentic reference compounds used in this study, to Dr. S. A. Kaplan, Mr. S. Cotler, and Mr. E. Postma for conducting the dog experiments, to Dr. A. S. Leon for conducting the clinical studies, and to Mr. R. McGlynn and Mr. T. Daniels for the drawings of the figures.

# New Method for Evaluating Topical Action of Substances on Gastric Mucosa

R. S. ALPHIN and D. A. DROPPLEMAN

**Abstract** □ A new method is described to evaluate the topical action of drugs on the gastric mucosa of laboratory animals. Of distinct advantage is the ability to assess the effects of more than one drug simultaneously on adjacent mucosal areas. The method also has proven to be of value in studying the effects of such variables as duration of exposure, pH, and pepsin.

**Keyphrases** □ Gastric mucosa injury—multidrug simultaneous evaluation, animals □ Aspirin—gastrotoxic effects, cats □ Phenylbutazone—gastrotoxic effects, cats

An important and well-known facet of the pharmacology of various substances, particularly anti-inflammatory drugs, is their injurious topical action upon the GI tract. Most methods used to determine such action have involved assessing the gastric effects following the oral administration of drugs to guinea pigs (1-3), rats (4), dogs (5, 6), rabbits (3), and man (7). Some investigators introduced the substances under investigation directly into the stomach of several species of animals (3, 8, 9). Direct application of anti-inflammatory drugs on the buccal mucosa of man (9) and the explanted gastric mucosa of dogs (10) also were studied. Few, if any, of these methods provide for the simultaneous assessment of the damage produced by two or more agents on adjacent areas of the gastric mucosa. The apparatus and procedure described in this report make such an evaluation possible and, in addition, allow the experimenter to observe the progression of some events as they occur.

## EXPERIMENTAL

**Apparatus**—A 10.2-cm. round bar of clear Plexiglas was bored to 6.5-cm. i.d. and cut into pieces 5.6 and 2.4 cm. in length for the two upper pieces of the apparatus. Two pieces of Plexiglas tubing (0.5 × 2.5 cm.) were glued into holes bored into opposite sides of the upper portion using Plexiglas solvent MC-25. Three holes were drilled down through the top ring and into the bottom ring; the bottom ring was threaded to receive 10-32 SS machine screws. Three machine screws were ground to a point for easier penetration of the mucosa.

A continuous groove, 0.3-cm. deep and 0.4-cm. wide, was cut in the center of the bottom surface of the upper ring where it contacts

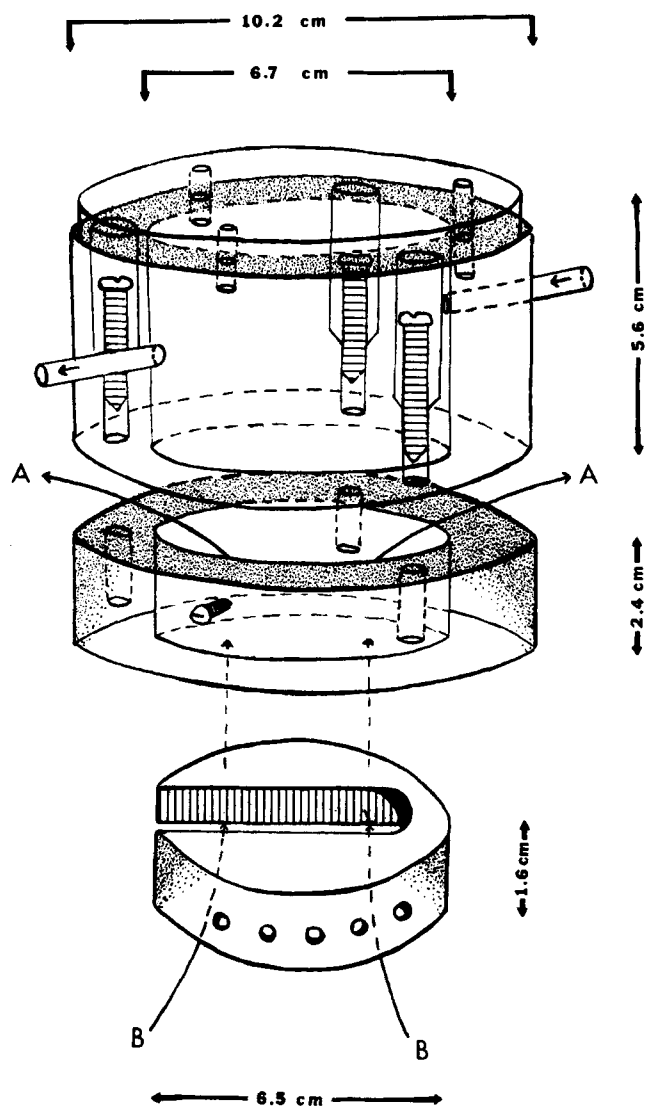

**Figure 1**—Diagram of the Plexiglas chamber used for assessment of topical effects of substances on the gastric mucosa. Key: A, position of the stomach wall and mucosa; B, direction of major blood vessels. The lower Plexiglas disk, when placed into position, provides a relatively flat mucosal surface.